

Horizontal Pillow Bag Machine

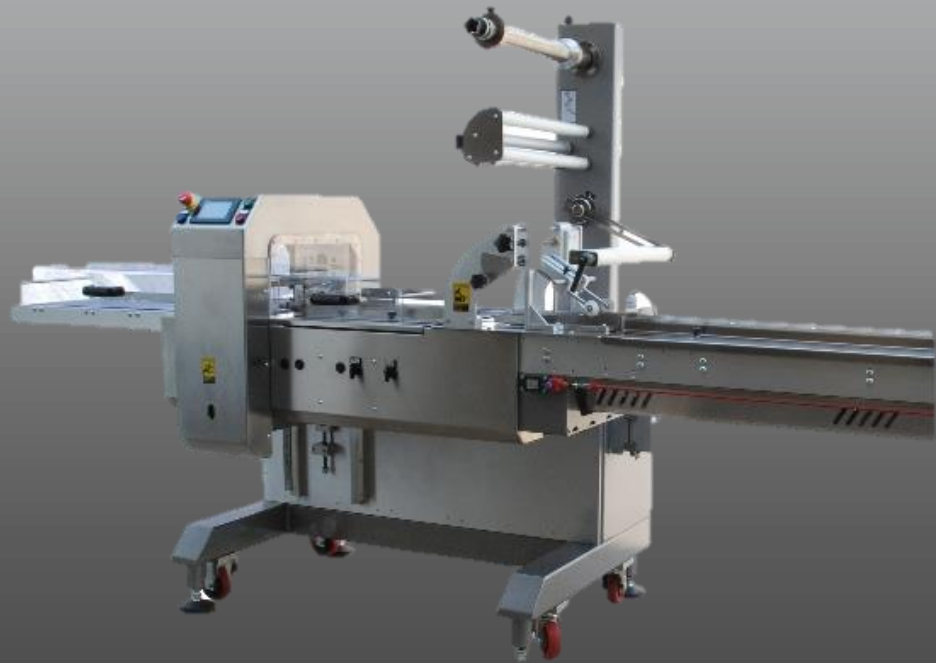

Film feeding from the top



Film feeding from the bottom

Machine Series: AHP

Horizontal Pillow Bag Machine – Film feeding from the top

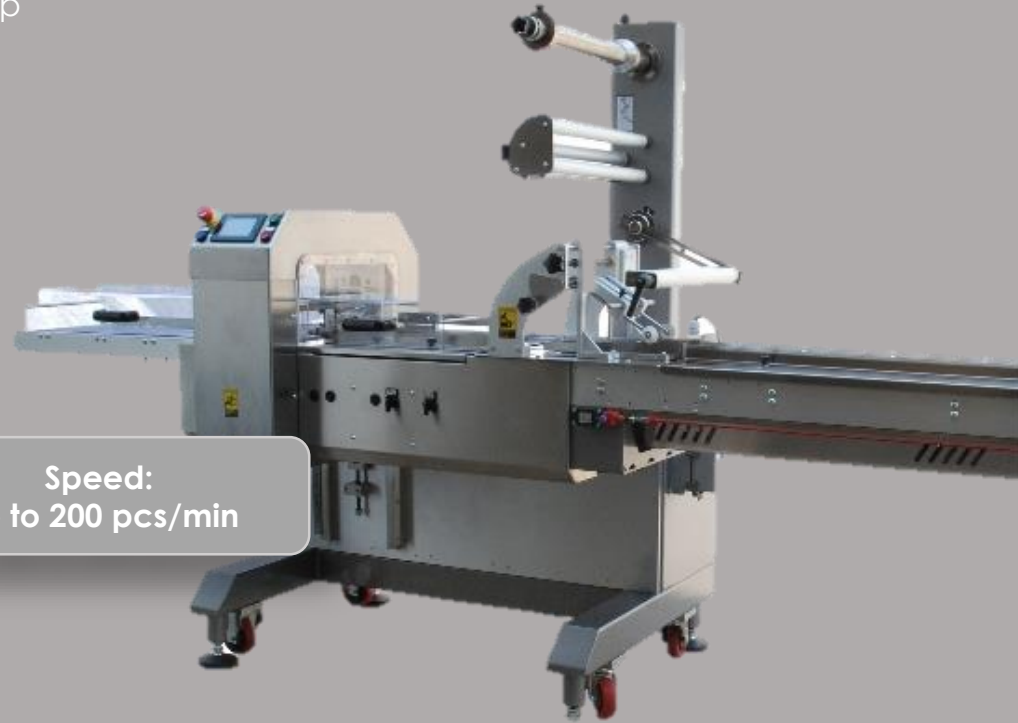

**Speed:
Up to 200 pcs/min**

Technical Details:

- Steel frame / stainless steel construction
- Products are transported by gripper loading
- Teflon-coated, permanently heated sealing stamps
- Simple touchscreen operation via color symbols
- Continuous feeding of the products by photocell control
- Safety protection covers / alarm signal lamp
- 3-sided sealed seam packaging (fin seam)

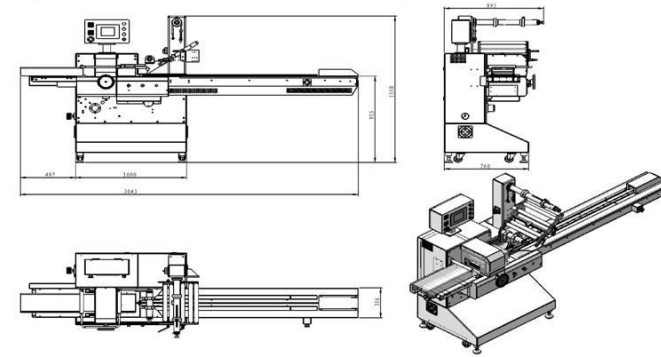

Machine Dimensions

Applicable Products:

Our AHP series (film from above) reliably packages among others the following products:

- Medical Products
- Fruit and Vegetables
- Technology
- Biscuits
- Frozen food

Model	AHP-400-1S	AHP-450-3S	AHP-450-3S mini	AHP-500-3S	AHP-600-3S
Applicable Films:	PP / POF / Composite Films	PP / POF / Composite Films	PP / POF / Composite Films	PP / POF / Composite Films	PP / POF / Composite Films
Speed:	UT 100 pcs/min	UT 90 pcs/min	UT 90 pcs/min	UT 200 pcs/min	UT 150 pcs/min
Sealing Mechanism 1 & 2:	longitudinal/rotation	Longitudinal/rotation /3 servomotors	Longitudinal/rotation /3 servomotors	Longitudinal/rotation /3 servomotors	Longitudinal/rotation /3 servomotors
Max. Product Height:	100 mm*	-	-	120 mm*	140 mm*
Max. Product Width:	200 mm*	-	-	250 mm*	300 mm*
Product Length:	40-550 mm*	Up to 600 mm*	Up to 400 mm*	60-550 mm*	70-550 mm*
Max. Roll Size:	400 x Ø 350 mm	450 x Ø 300 mm	450 x Ø 300 mm	500 x Ø 350 mm	600 x Ø 350 mm
Max. Connected Load:	2,5 kW	3,0 kW	3,0 kW	3,0 kW	3,5 kW
Air Pressure (dry air):	6,0 bar	6,0 bar	6,0 bar	6,0 bar	6,0 bar
Supply Voltage:	400 V / 3-phases	400 V / 3-phases	400 V / 3-phases	400 V / 3-phases	400 V / 3-phases

Maschinenserie: AHP

Horizontal Pillow Bag Machine – Film feeding from the bottom



Speed:
Up to 60 pcs/min

Technical Details:

- Steel frame / stainless steel construction
- The products are transported by gripper loading
- Teflon-coated sealing stamps, permanently heated
- simple touchscreen operation via color symbols
- continuous feeding of the products by photocell control
- Safety protection covers / alarm signal lamp
- 3-sided sealed seam packaging (fin seam)



Bag Dimensions:

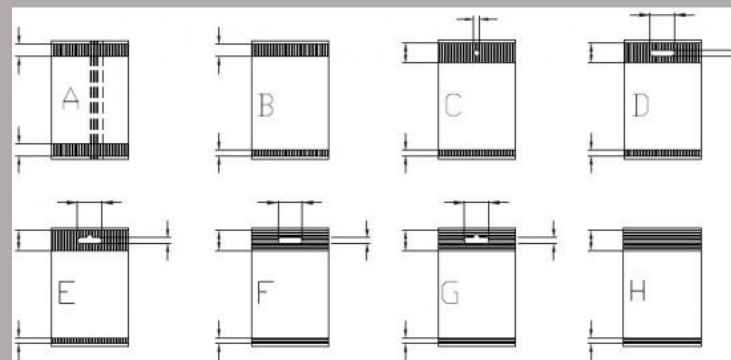

Applicable Products:

Our AHP series (film from below) reliably packages the following products:

- Medical products
- Fruit and vegetables
- Technology
- Biscuits
- Frozen food

Model	AHP— 500-3S-BR	AHP-500- 4S-BRI	AHP-600- 3S-BR	AHP-600- 4S-BM	AHP-700- BM	AHP-70 0-4S-BRI
Usable films:	PP / POF / Composite films	PP / POF / Composite films	PP / POF / Composite films	PP / POF / Composite films	PP / POF / Composite films	PP / POF / Composite films
Speed:	Up to 120 pcs/min	Up to 60 pcs/min	Up to 120 pcs/min	Up to 60 pcs/min	Up to 70 pcs/min	Up to 60 pcs/min
Sealing Mechanism 1 & 2:	longitudinal, rotation, servomotor	longitudinal, rotation, servomotor	longitudinal, rotation, servomotor	longitudinal, rotation, servomotor	-	longitudinal, rotation, servomotor
Max. Film Width:	-	700 mm	-	600 mm	-	700 mm
Max. Bag Length:	-	50-600 mm*	-	50-600 mm*	-	50-600 mm*
Max. Sealing Height:	-	120 mm*	-	120 mm*	-	120 mm*
Max. Product Height:	-	-	120 mm*	-	120 mm*	-
Max. Product Width:	-	-	280 mm*	-	-	-
Max. Roll Size:	-	-	600 x Ø 300 mm	-	-	-
Max. Connected Load:	-	-	3,5 kW	-	6 / 9 kW	-
Supply Voltage:	-	-	400 V / 3- phases	-	400 V / 3- phases	-

Additional Options:

Horizontal Pillow Bag Machine – AHP Series

Optional features for our AHP series:

- Box-Motion for high speed production
- Thermal transfer printer (best before date)
- Stainless steel construction
- Cooling applications for ice packaging
- Zig-Zag knife, Euro hole punches etc.
- Automatic stop for empty products
- Applications for shrink films (Flow Shrink)
- Gassing units for protective atmosphere (extend product shelf life)
- Automatic product feeding systems, cyclical insertion systems
- Perforation units (tear strip) for easy opening
- Length-independent product processing through photocell scanning

Optional Accessories:

- Photocell
- Printer (e.g. for sell-by dates)
- Stainless steel construction
- Transmission for Auto Feeder



Product Samples:



About alpha-pack GmbH

With decades of experience, the **family-owned manufacturing companies** of Alpha-Pack Group GmbH rank among the pioneers in the packaging industry - We live innovation and progress. Unique to the market, we offer system solutions for the integrated packaging process in our corporate group, including suitable consumables - **Everything from one single source without intermediate trade.**

Thanks to our **many years of experience**, we are experts in developing, producing and selling packaging machines. Since our foundation, we have been dedicating ourselves to the development and introduction of **advanced equipment and technologies..** Due to the expansion of our mature and international brand and distribution network, our packaging machines have so far been exported to **more than 50 countries and regions.**

alpha-pack GmbH – smart packaging solutions by manufacturers

* The output quantities per minute are average values, depending on film type and thickness, product dimensions and machine handling. It is not possible to combine all maximum dimensions. We reserve the right to make technical changes or changed output values exclusively.

smart packaging solutions by manufacturers



For further questions about our packaging machines and services, please contact us at:

alpha-pack GmbH
Otto-Hahn-Allee 1
50374 Erftstadt

+49 2235-79479-0

info@alphapack.de

www.alpha-pack.de